



MODULAR 4-WAY VALVES

R-462

4-Way Valve, 6-Ported

Features:

- Indicator shows valve in shaded position
- Micro gap construction - snap action and no blow by
- Balanced design allows speed control at exhausts

Performance:

Flow: 9 scfm @ 100 psig; 255 l/min @ 6.9 bars
Pilot Pressure Minimum: 20 psig; 1.4 bars
Temperature: 32° to 180° F
Working Pressure: 0 to 150 psig; 0 to 10.3 bars

Description:

R-462 is a 6-ported, 4-way, double piloted, fully ported, two position valve. It is basically two fully ported 3-way valves with a common pilot. It can be used in a variety of applications including dual pressure operations with two independent inlets, outlets and exhausts.

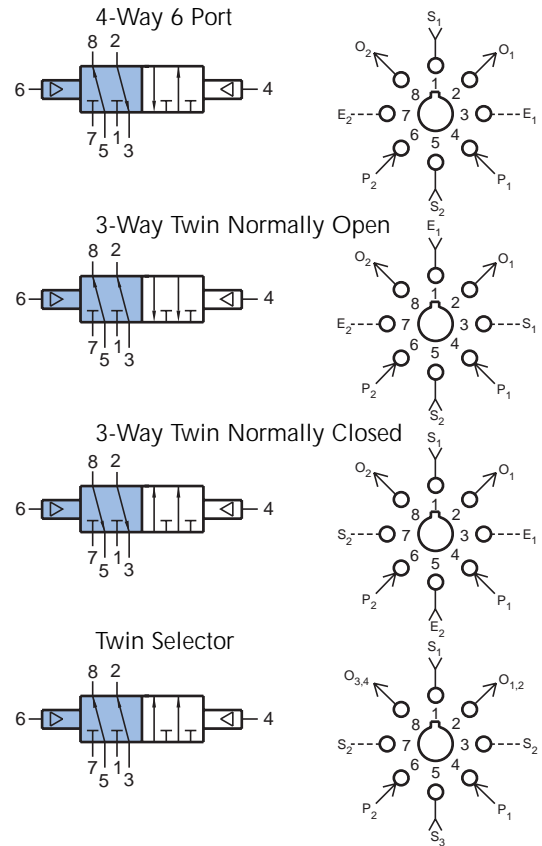

R-465

Low Pressure 4-Way Valve, 6-Ported

Features:

- Pilot actuates valve with low pressure signal
- Multiple porting speeds piping
- Micro gap construction - snap action and no blow by
- Balanced design allows speed control at exhausts

Performance:

Flow: 9 scfm @ 100 psig; 255 l/min @ 6.9 bars
Pilot Pressure Minimum: 15 psig; 1.0 bar
Temperature: 32° to 180° F
Working Pressure: 0 to 150 psig; 0 to 10.3 bars

Description:

R-465 is a 6-ported, 4-way, spring-return, fully ported valve with a low pressure pilot. Pilot pressures as low as 15 psig will actuate the valve. It is basically two fully ported 3-way valves with a common low pressure pilot. It can be used in a variety of applications including dual pressure operation, with two independent inlets, outlets and exhausts. The R-465 may be used in place of an R-461 where a lower pilot actuation pressure is desired.

